

Air Preheat System Upgrade on Coker Heaters

Ashutosh Garg
Furnace Improvements



Air Preheat System

- Not popular
- Misconception about NOx emissions
- Number of APH installations not in use
- Heaters operating in Natural draft mode losing energy
- Energy prices are very low ??
- Our fired heaters are not very efficient
- But???



Two identical Balanced Draft
Coker Heaters -
Heat duty of each heater -
126.8 MMBtu/hr

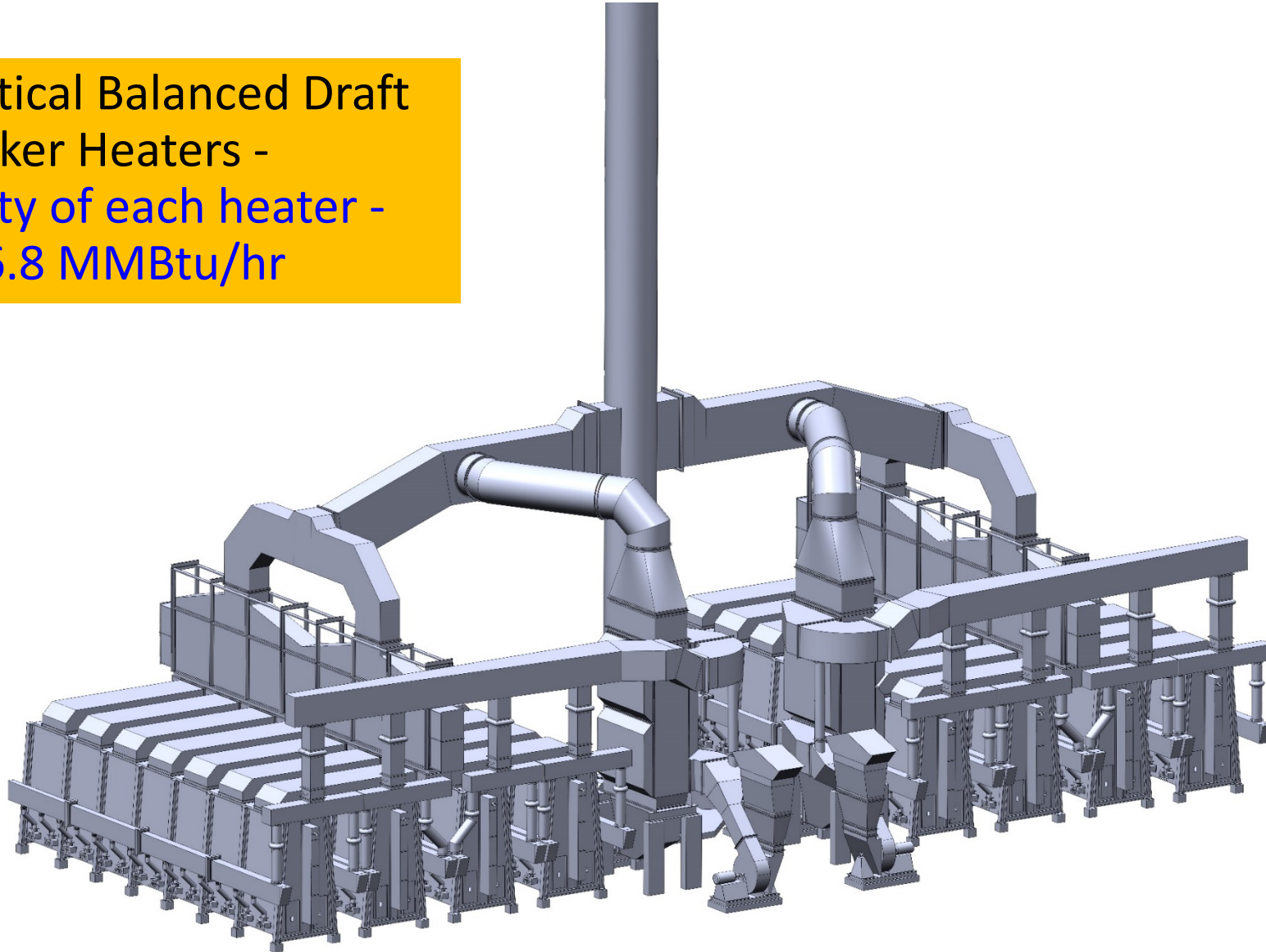

Existing Air Preheat System

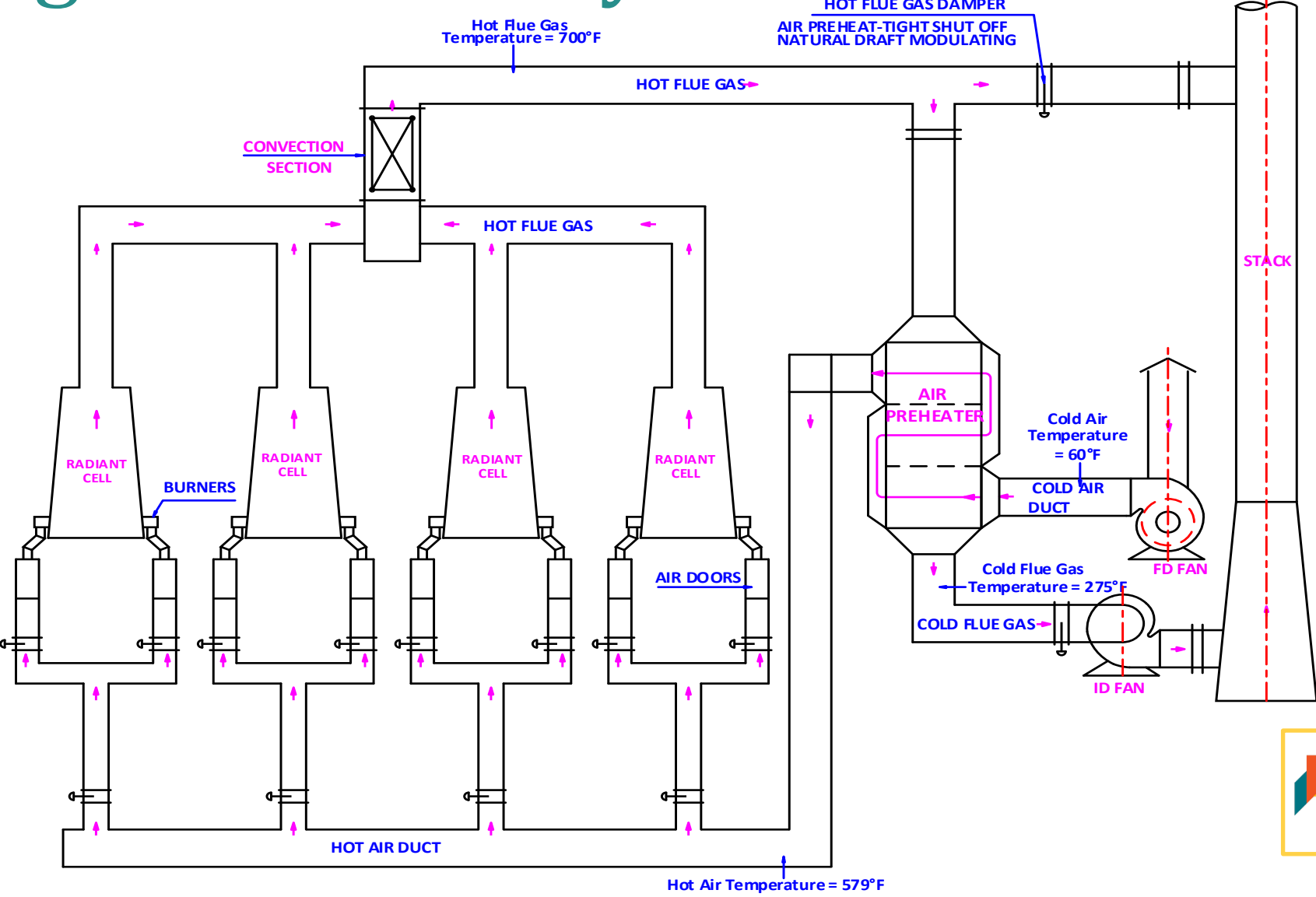

Operating Issues with Air Preheating Systems

- Air Preheater
 - Corrosion
 - Air leakage
 - High flue gas side pressure drop
- Bypass duct limitation
- Burners
 - Non uniform air flow to burners
- Flue gas bypass to stack, ID fan limiting
- Client was throughput limited



Air Preheater Problems

- Low tube metal temperature and excessive corrosion problems:
 - Non- uniform air flow distribution
 - Cold zones in static air preheater
 - APH Design was deficient with respect to acid dew point corrosion



Existing Air Preheater

- Type-Recuperative Cast Iron
- Heat Duty- 15.05 MMBtu/hr
- Flue Gas Side Details
 - Flowrate- 130,150 lb/hr
 - Inlet/Outlet Temperature - 700°F/ 275°F
 - Pressure Drop- 2.0 inches WC
- Air Side Details
 - Flowrate- 117,700 lb/hr
 - Inlet /Outlet Temperature- 60°F/ 579°F
 - Pressure Drop- 4.3 inches WC
- ❖ Minimum Tube Metal Temperature- 230°F



APH System

Existing Air Preheater was corroded and leaking air into flue gas



Existing FD Fan

- ❖ Fan rated for 34,652 acfm at 120°F with 10.5inch W.C pressure rise (TB)
- ❖ Drive Arrangement- #7 SWSI
- ❖ Fan Speed- 1,200 rpm
- ❖ Motor - 100 H.P
- ❖ Steam APH is provided at the inlet
- ❖ Inlet guide vanes to control the flow
- ❖ Provided with 20 ft tall suction stack consisting of rain hood with screen, silencer and steam APH coils

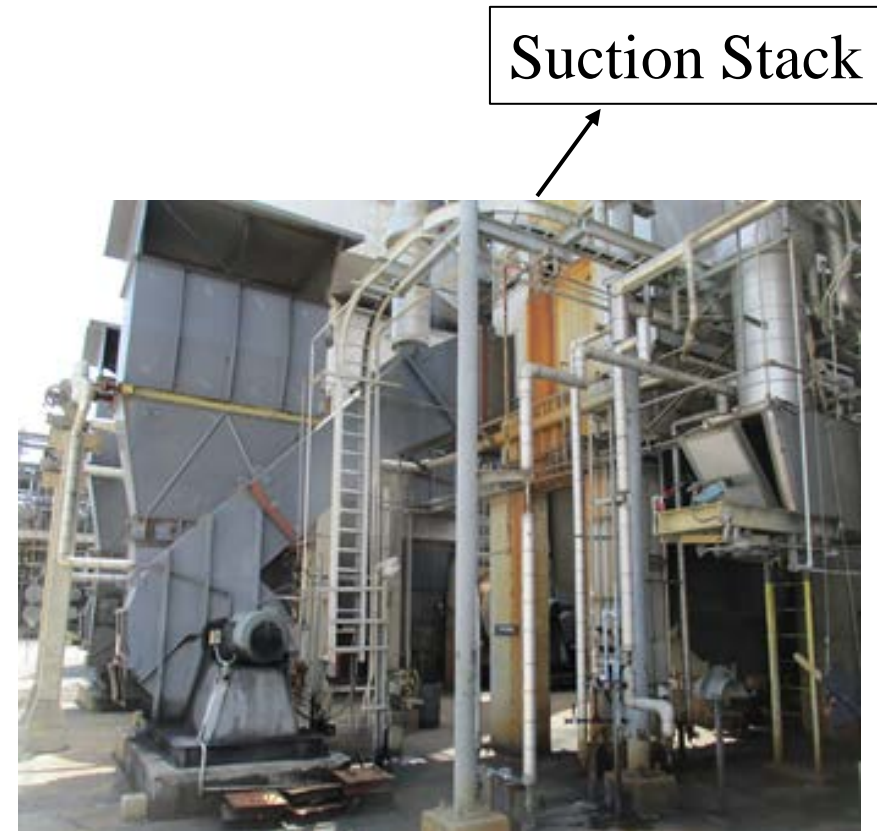

Forced Draft Fan

Existing FD fan was limiting due to APH leakage
Suction filter was getting clogged with coke particles



Existing Steam Air Preheater

- ❖ Provided at FD Fan inlet duct to preheat air in winter to avoid Acid Dew Point Corrosion in main APH
- ❖ Heat Duty- 1.61 MMBtu/hr
- ❖ Air inlet / outlet temperature : 10 °F / 60 °F



Existing steam air preheater was undersized and getting clogged with coke particles

Steam APH Coils



Existing ID Fan

- ❖ Rated for 58,530 acfm at 350°F with 5.1 inch WC static rise (TB)
- ❖ Arrangement- #7 SWSI Grade Mounted
- ❖ Inlet pneumatically operated damper to control the flow
- ❖ Fan Speed- 900 rpm
- ❖ Motor- 75 HP



Induced Draft Fan

ID fan was undersized and was limiting



Limitation of the Heaters and APH System

❖ Heater

- High flue gas convection section exit temperature, almost 30-40% flue gas bypassing the air preheater (calculated thermal efficiency -85%)

❖ Air Preheater

- Acid Dew Point or Cold Block Corrosion

❖ ID & FD Fans

- ID and FD fans were limited in capacity thereby limiting the heater production

❖ Combustion / Cold Air By-pass Duct was undersized



Flue Gas Temperature Leaving Convection

Flue gas temperature to Air Preheater is higher by almost 100-180F

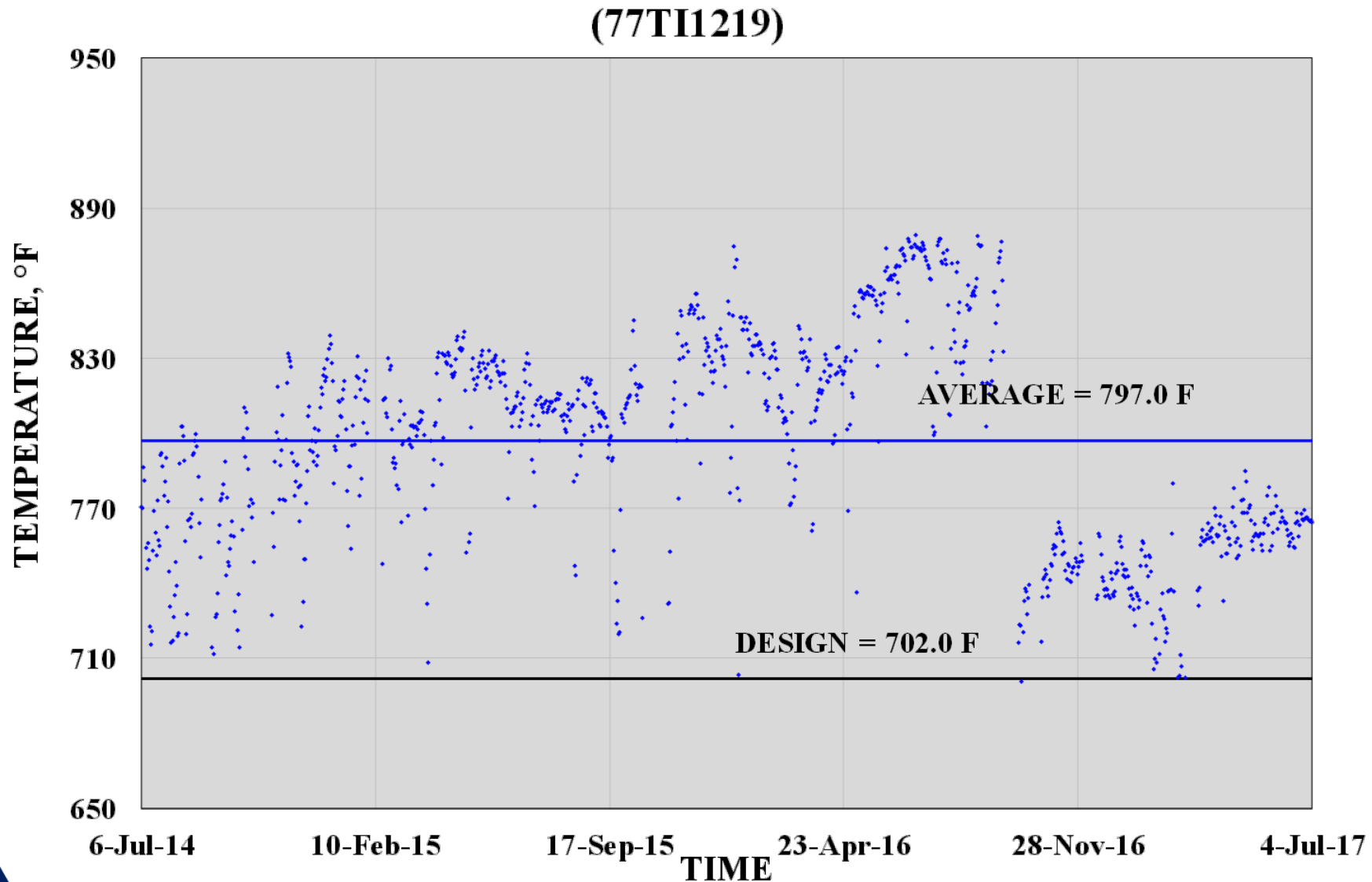

Air Preheating System Modifications

- Systems approach:
- Installation of new APH, FD fans, ID fans, Steam APH
- Modification of combustion air and flue gas ducts
- Installation of additional convection tubes

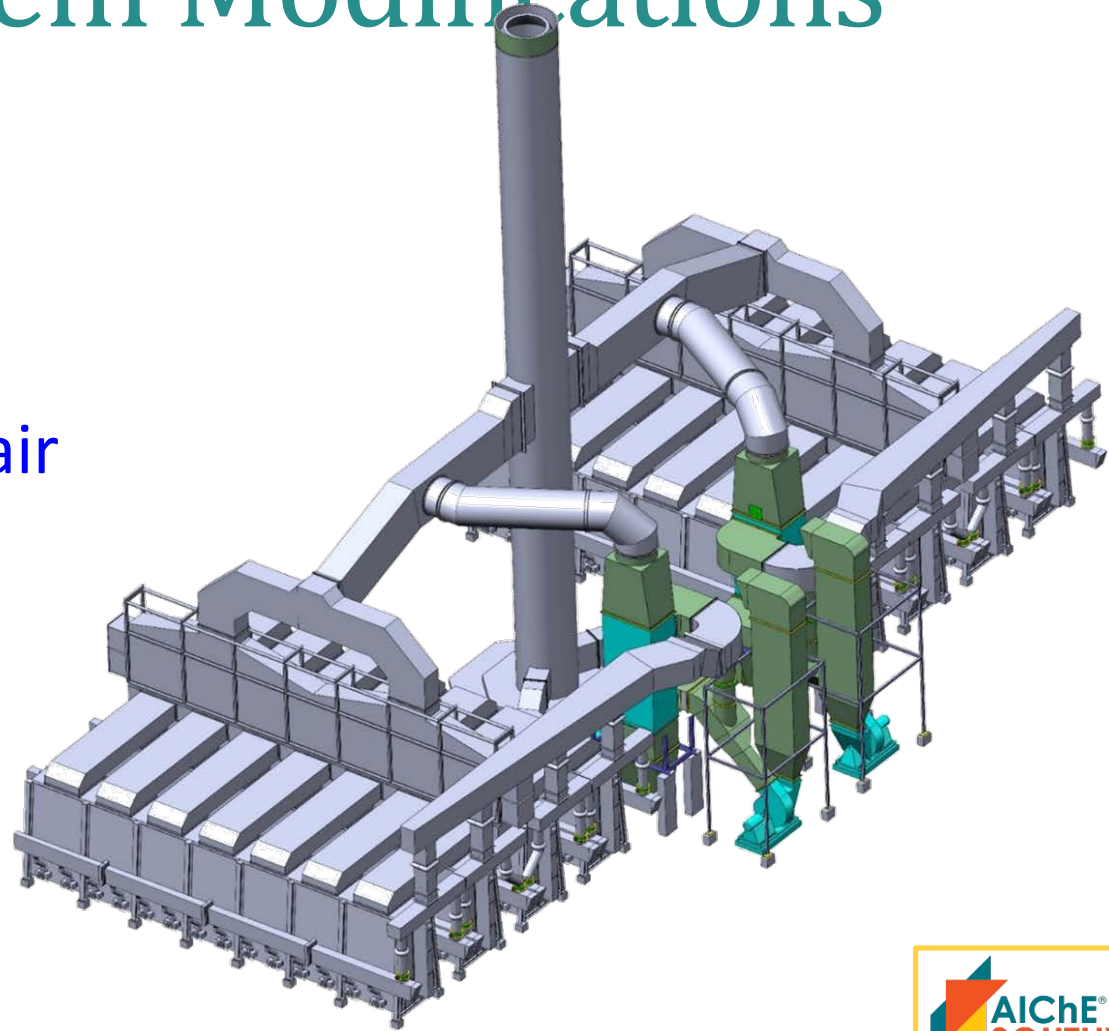

Addition of Process Coils in Convection

- Two future rows provision to be used.
- Fin configuration of process coils in future rows: 1" ht. x 0.06" thk. X 5 FPI
- 8,858 ft² additional heat transfer area in process convection
- Flue gas temperature leaving the convection section is reduced from 834°F to 701°F

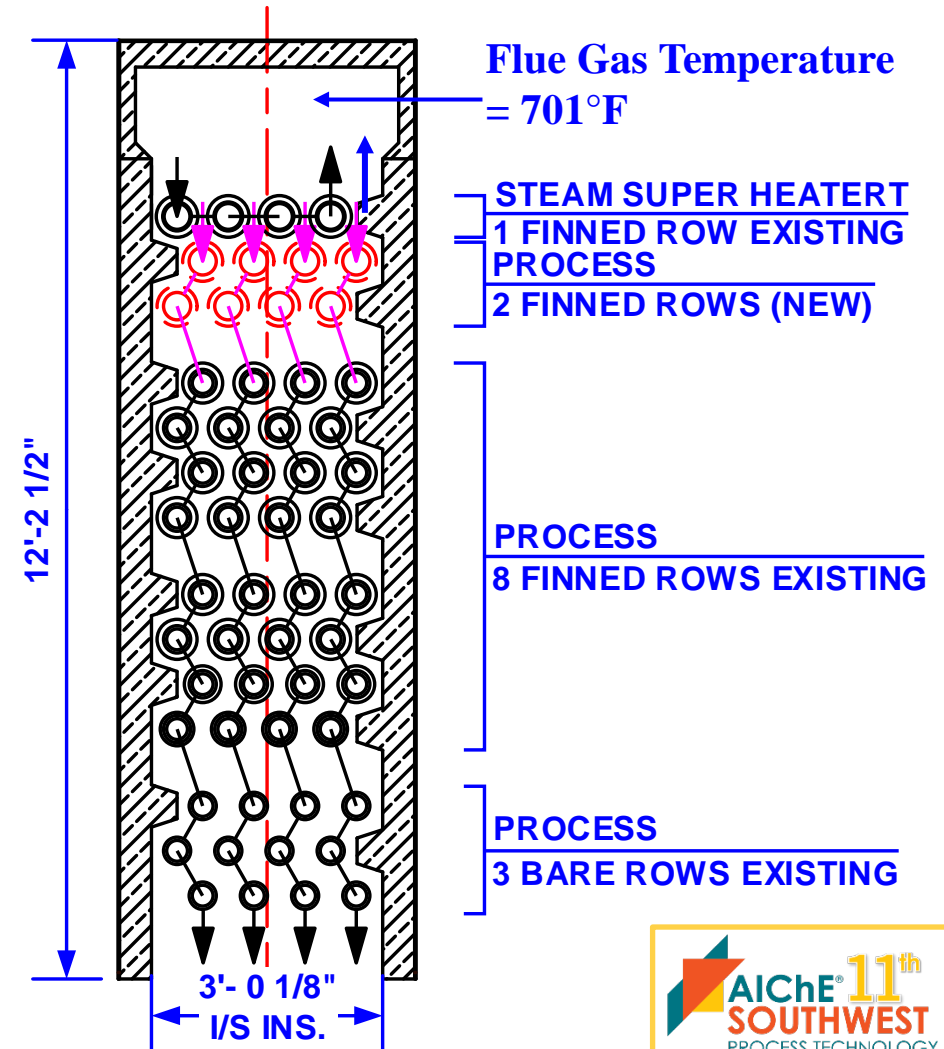

Proposed Convection Section



Air Preheater Recommendations

- New Plate Type APH
- Preheater design revised to 300°F flue gas temperature
- 20% higher flue gas flow rate
- Steam air preheater upstream to ensure constant air temperature of 120°F
- Glass /Ceramic Coating on metal plates to avoid dew point corrosion in cold end.
- ❖ Design Heat Duty of 17.7 MMBtu/hr..
- ❖ Minimum tube metal temperature (TMT) of 279°F

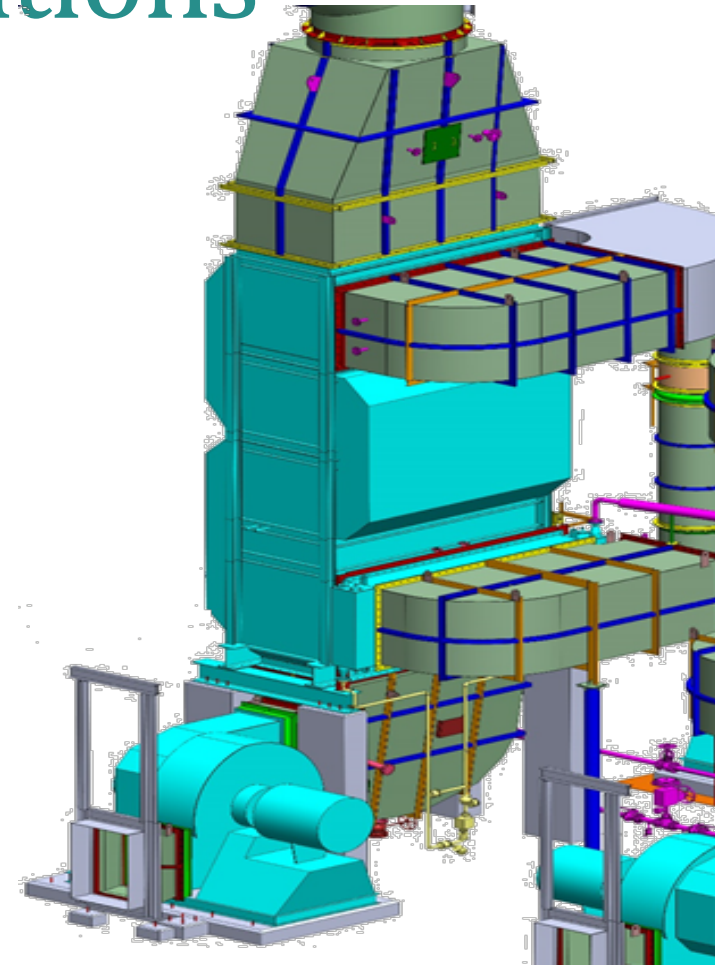

Existing and Proposed APH Comparison

Parameter	Unit	Existing	Proposed
Absorbed Duty	MMBtu/hr	15.05	17.7
Air Flow Rate	lb/hr	117,700	155,038
Air Inlet / Outlet Temperature	°F	60 / 579	120 / 585
Flue Gas Flow Rate	lb/hr	130,150	162,714
Flue Gas Inlet / Outlet Temperature	°F	700 / 275	701 / 300
ΔP on Air Side (allowable/calculated)	in WC	- / 4.3	4.3 / 2.6
ΔP on Flue Gas Side (calculated)	in WC	2.0	2.9
Minimum Metal Temperature	°F	230	278.6

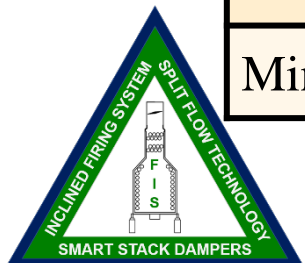

Existing vs. Proposed FD fan

Parameter	Unit	Existing	Proposed
Combustion Air Flow Rate	lb/hr	141,240	168,832
Air Temperature	°F	120	125
Static Pressure Rise	inch WC	10.5	14.07
Maximum Fan Speed	rpm	1,200	1,200
Motor Rating	HP	100	150

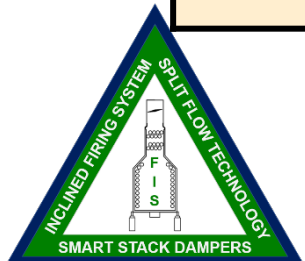

Existing vs. Proposed ID fan

Parameter	Unit	Existing	Proposed
Flue Gas Flow Rate	lb/hr	156,180	207,249
Flue Gas Temperature	°F	350	400
Static Pressure Rise	inch WC	5.0	10.62
Maximum Fan Speed	rpm	900	1,200
Motor Rating	HP	75	200

New ID fan motor is three times larger than the existing ID fan motor



Ducting Modifications

1. Combustion Air Duct Modification

- FD fan suction stack:
 - Additional 20 ft FD fan suction stack
- Cold Air bypass duct:
 - Size increased from 1'-8" (current size) to 3'-4"
 - Sized for Full Air Flow during forced draft operation
- FD fan discharge duct:
 - Smoother transition to APH
 - Angled baffle plates and turning vanes



Ducting Modifications

- Hot Air Duct Modification:

- Smooth outlet transition from APH with turning vanes
- Guide vanes and baffles
- Pressure drop plate to increase the air side pressure drop to 0.68 inch WC in burners

2. Flue Gas Duct Modification

- Hot Flue Gas Duct Modifications

- Inlet transition to APH has gradual expansion with angled baffles

- Cold Flue Gas Duct Modifications

- New duct with turning vanes



New FD fan Suction Stack

- 40 ft height from FD fan flange inlet (20 ft more than existing suction stack)
- 90 degree elbow
- Provided with fine wire mesh screen to block bird feathers entering APH

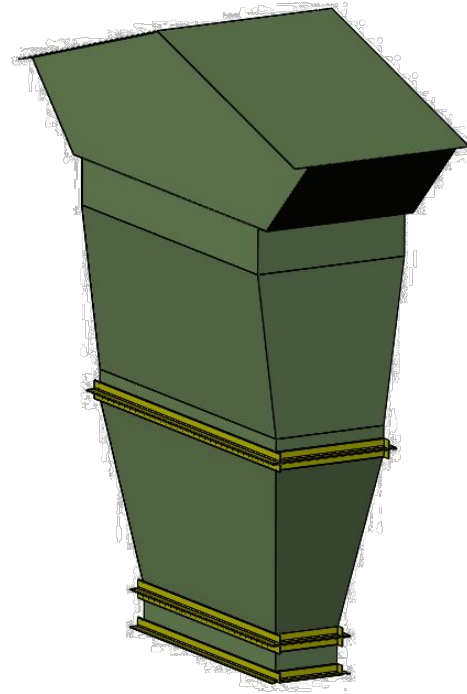

Existing
(20 ft)

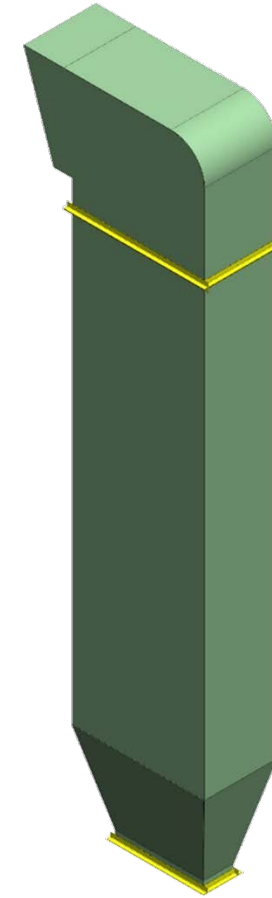

Proposed
(40 ft)



New Cold Air Bypass Duct

- Increased size to 3'-4" from 1'-8" (outside plate)
- Controlled by pneumatically operated, tight shut off damper

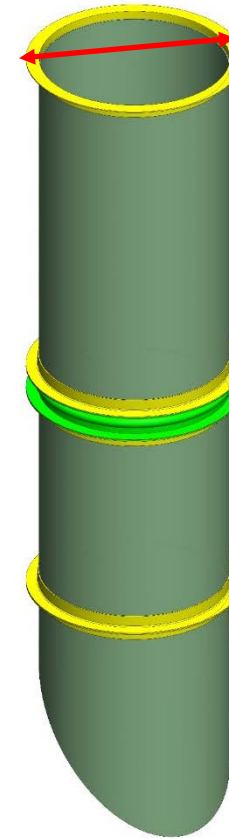

3.25 ft
o/s Plate
diameter

Proposed Bypass
Duct



Steam Preheat Coil

Parameter	Unit	Existing Steam Preheater	New Steam Preheater Coils
Heat Duty	MMBtu/hr	1.61	6.11
Air Inlet Temperature	°F	10	10
Air Outlet Temperature	°F	60	180



Picture of Steam Preheat Coil in Manufacturing Facility



Existing v/s New Steam Preheater



Existing
Steam APH
In Fan
Suction

Existing Steam APH Layout

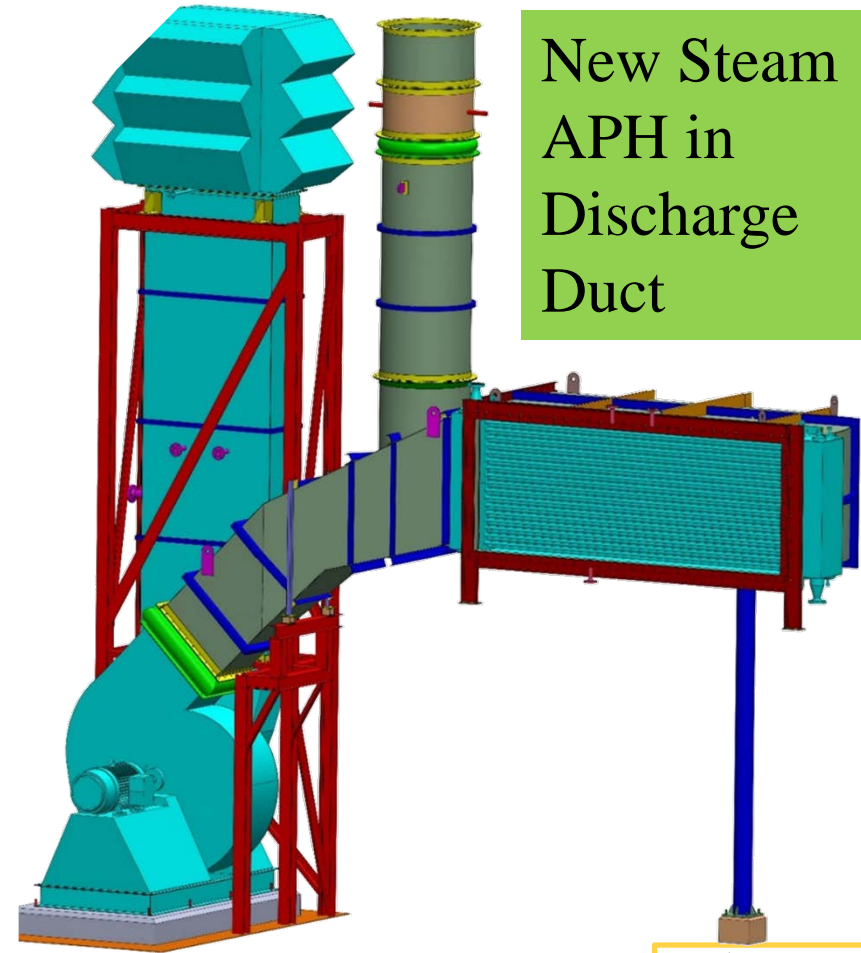

New Steam
APH in
Discharge
Duct

Proposed Steam APH Layout



Existing and Proposed FD fan Discharge Duct

Smoother Transition, Angled baffles and turning vanes provide uniform air flow

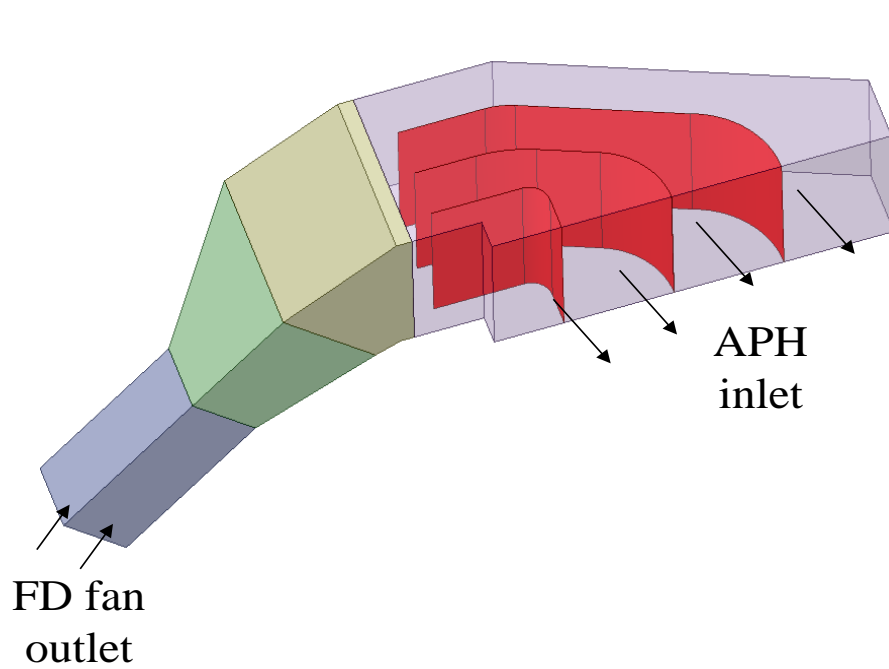

Existing

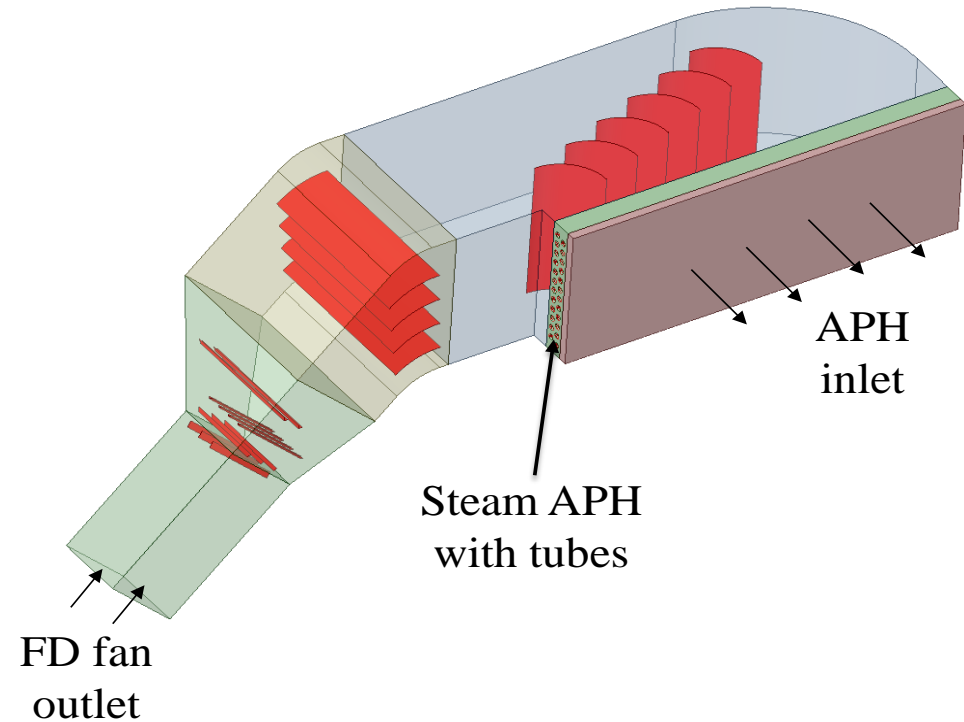

Proposed



Velocity RMS Deviation at APH Inlet

[ft/s]

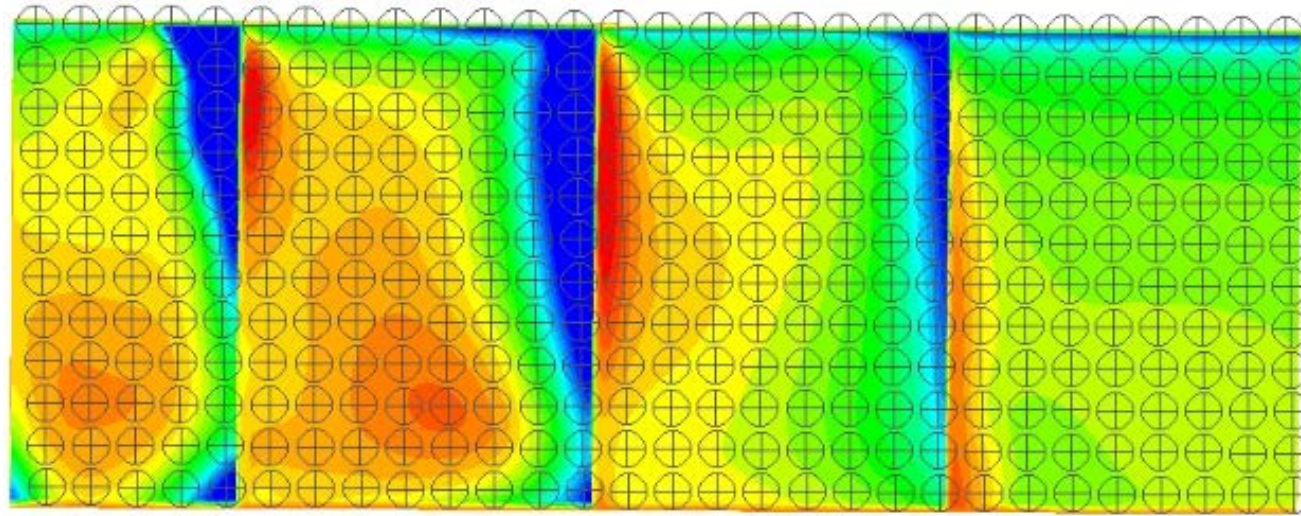
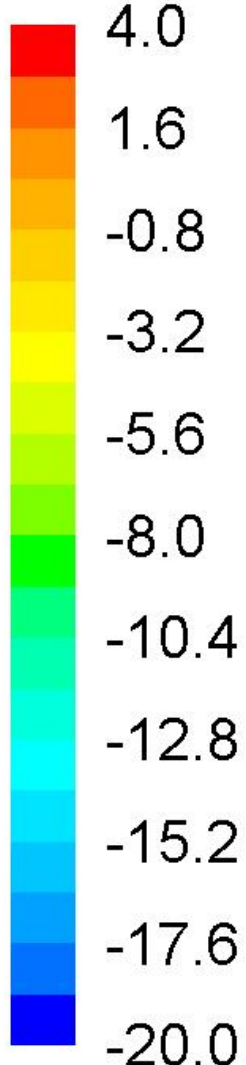

Normal velocity profile at APH inlet (after Steam APH)

Due to physical constraints on duct shape it was not feasible to further improve the flow distribution

Note: Recommended RMS Deviation of velocity is in the range of $\pm 5\%$

Existing

RMS deviation at APH inlet is: $\pm 91.0\%$

RMS deviation at APH inlet is: $\pm 13.9\%$

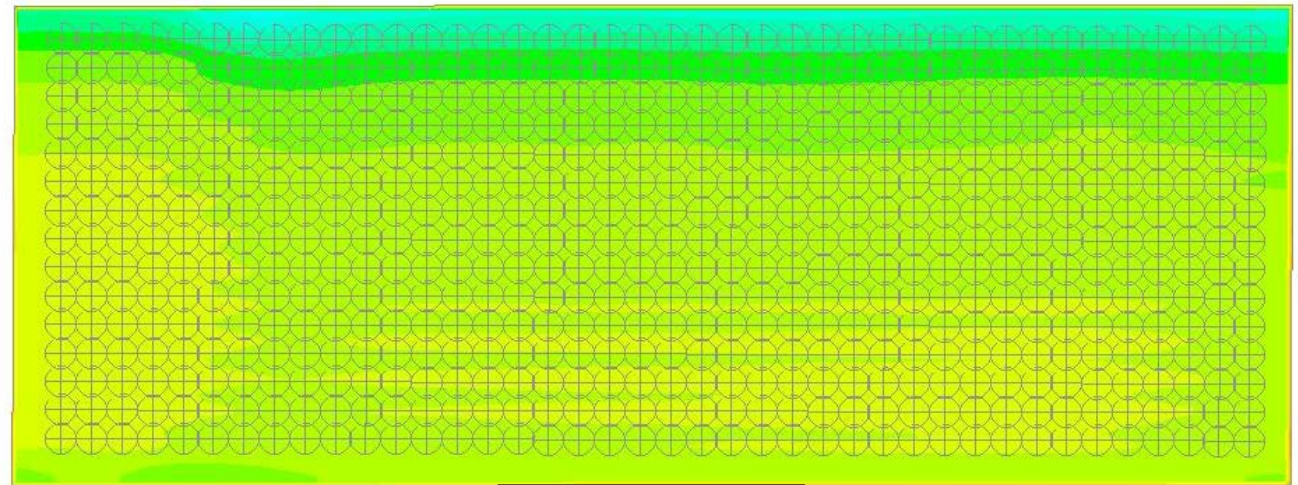

Proposed

PROCESS TECHNOLOGY
CONFERENCE

Hot Air Duct Modification for Uniform Air Flow

- Air preheat outlet
- Smooth and turning vanes are added
- Reduced dead zones and recirculation

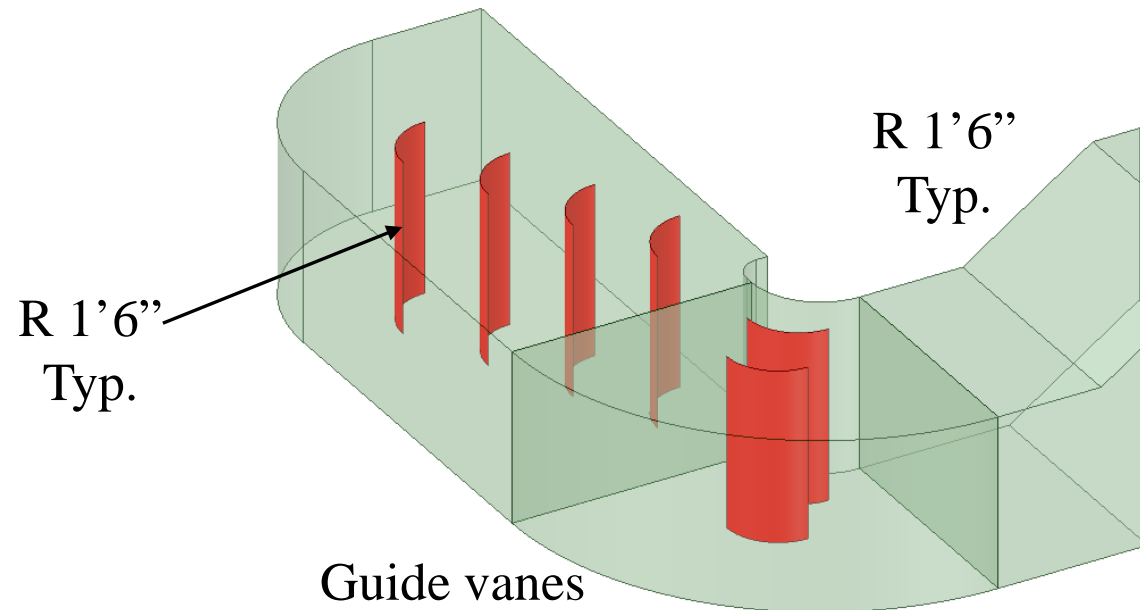

HA-2N duct modification



Air Flow Path Lines colored by Velocity

[ft/s]

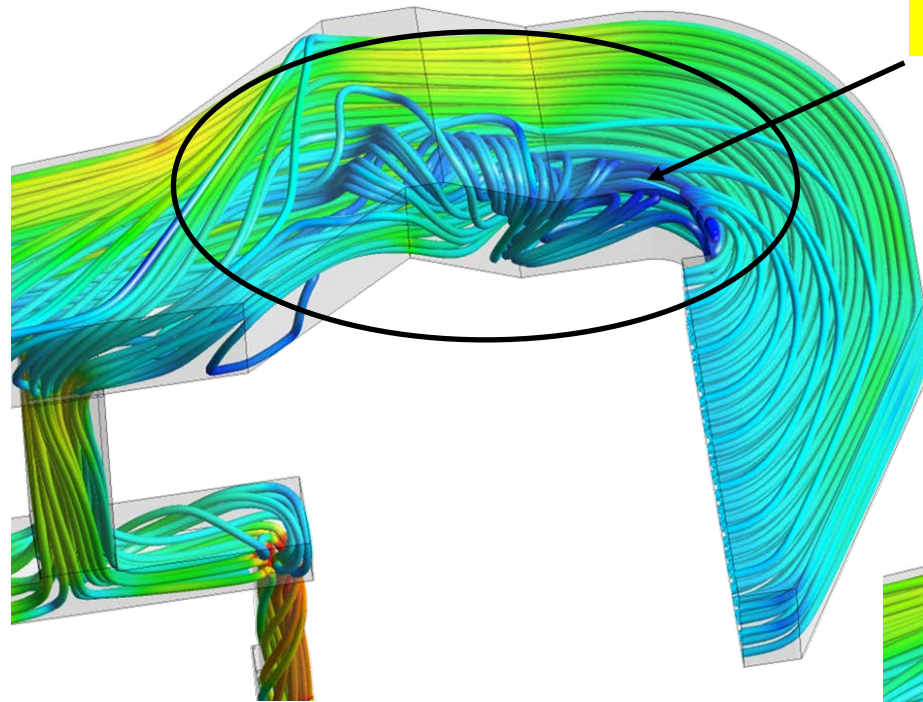
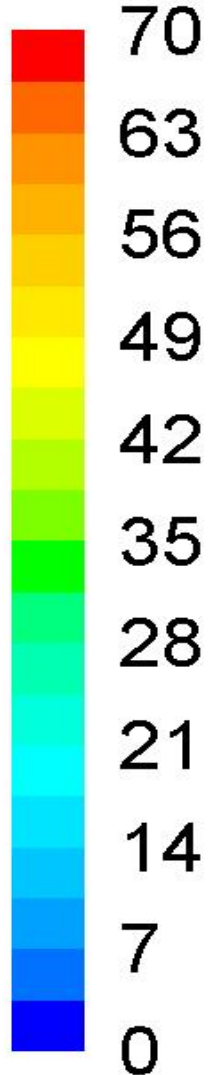

Existing

Recirculation

- Recirculation is reduced as compared to existing case with change in duct design and adding turning vanes
- Pressure drop is reduced by 0.05 inches WC as compared to existing design

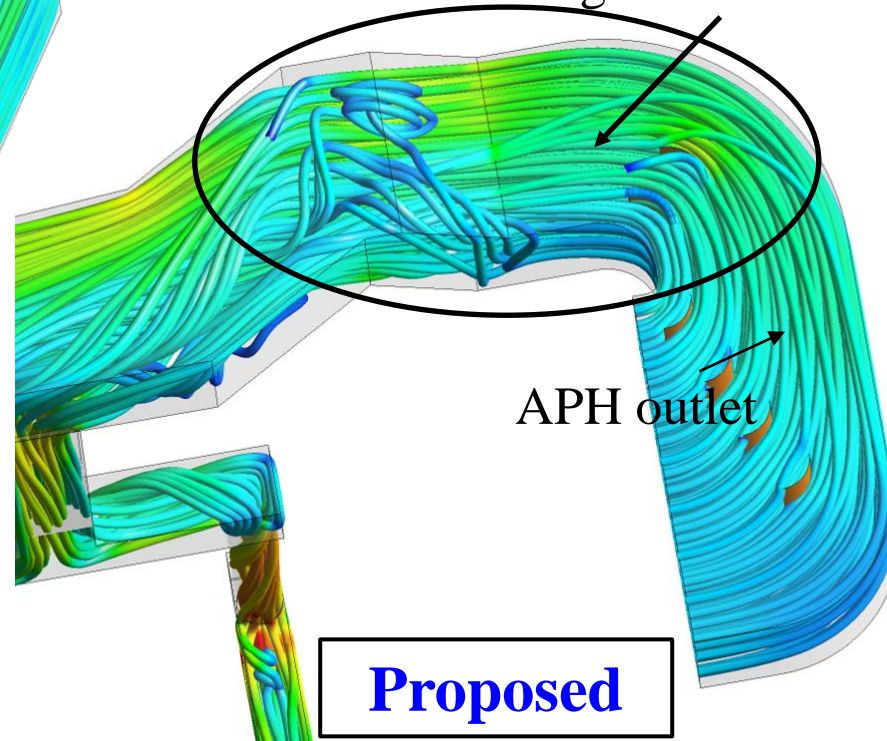

Proposed

APH outlet

Hot Air Duct Modification for Uniform Air Flow to Burners

Pneumatic Operated Dampers

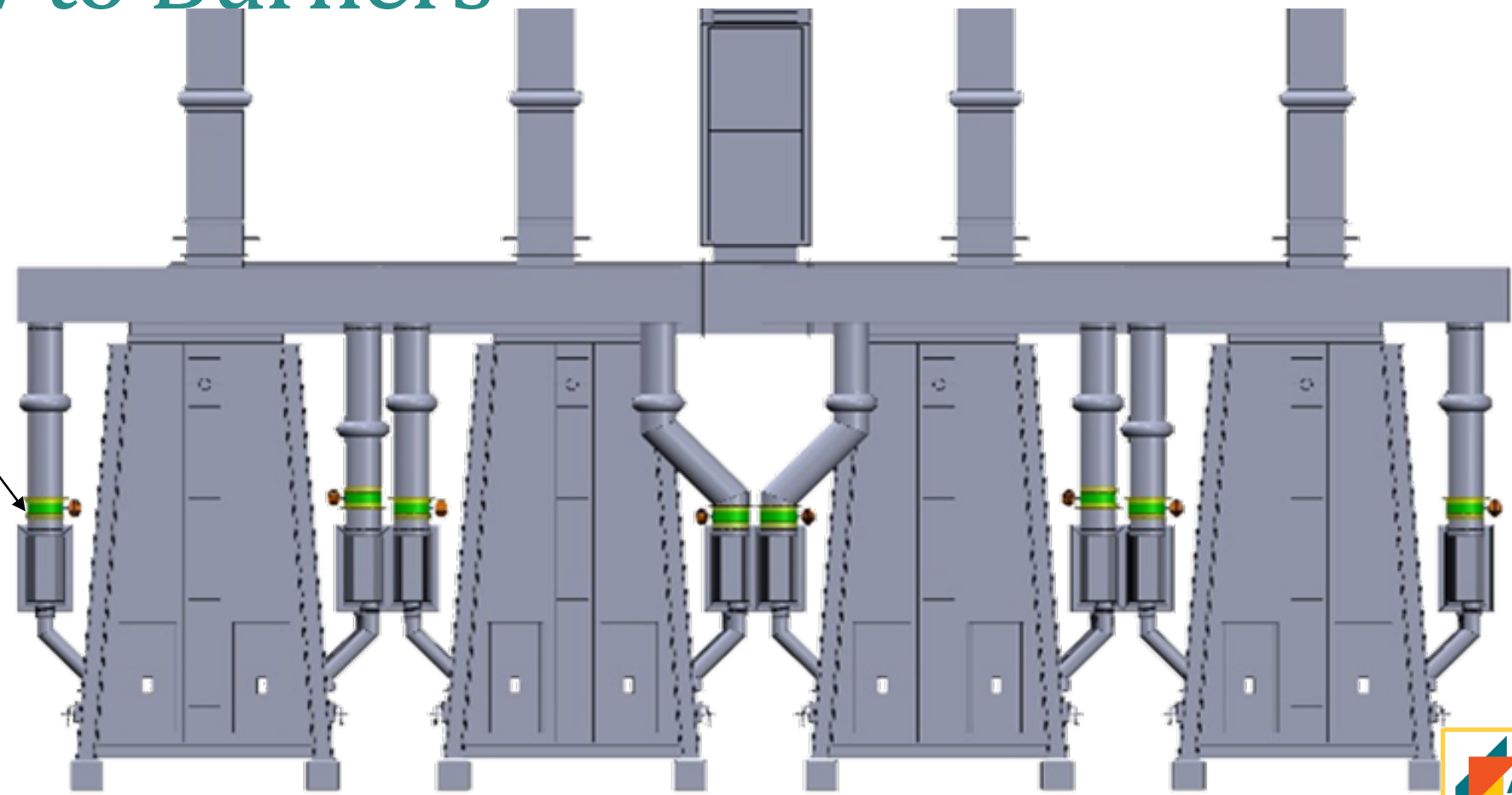

Hot Air Duct – Proposed Geometry

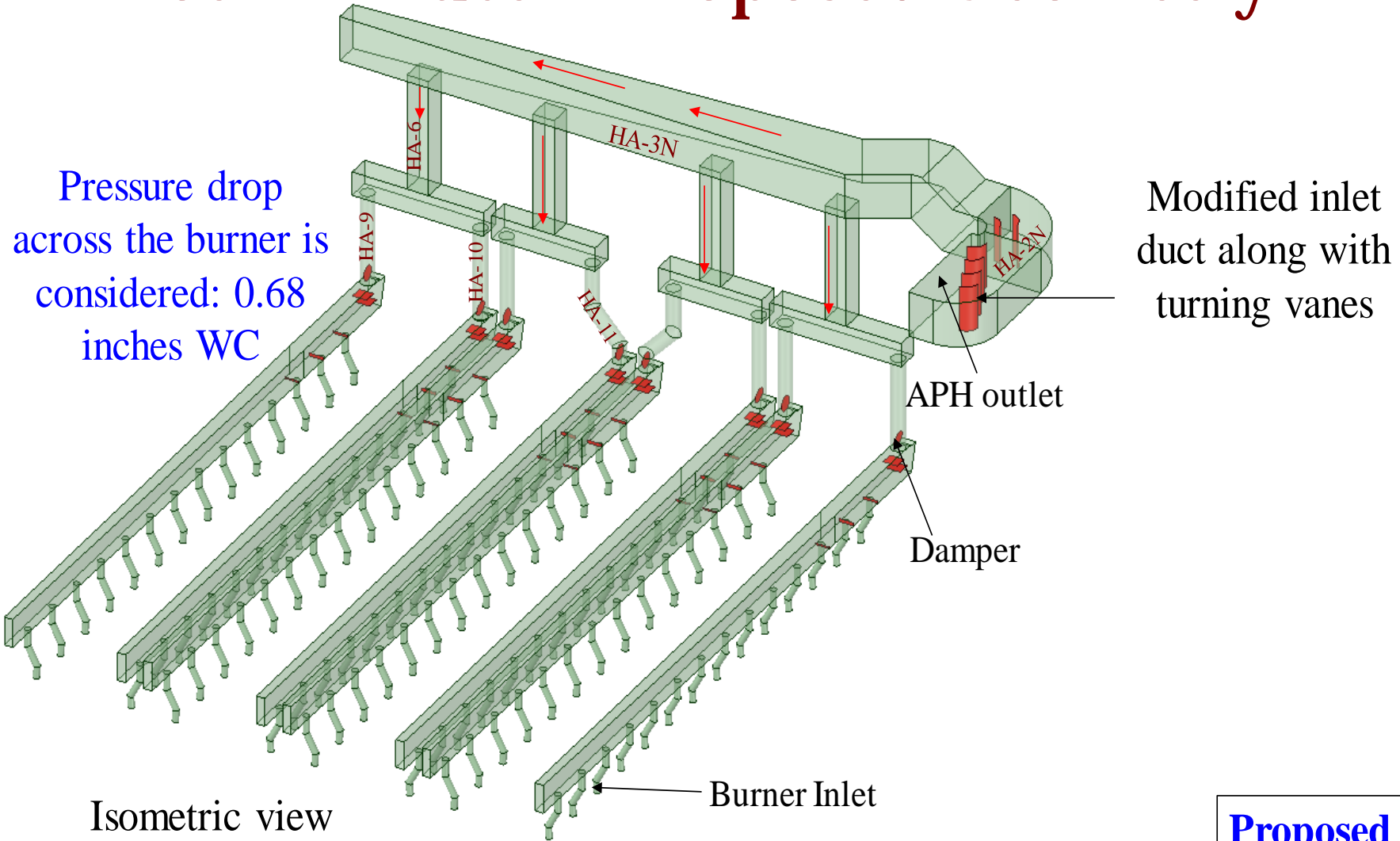

Proposed



Air Flow Variation to Burners

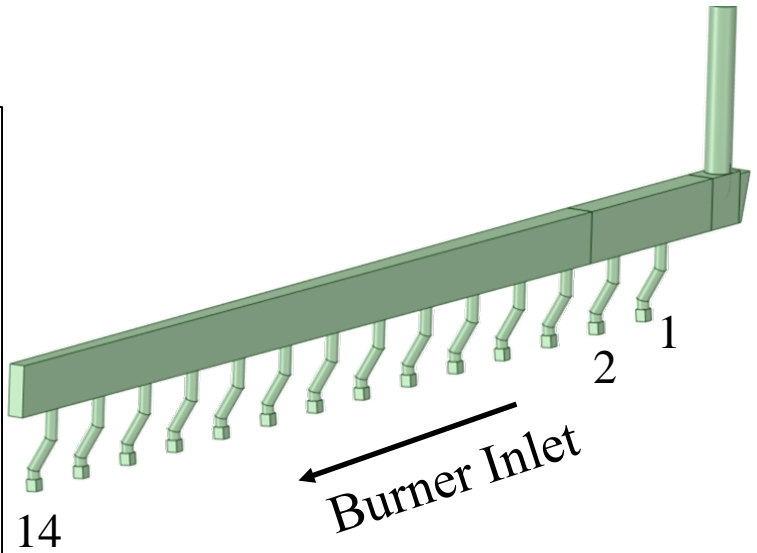
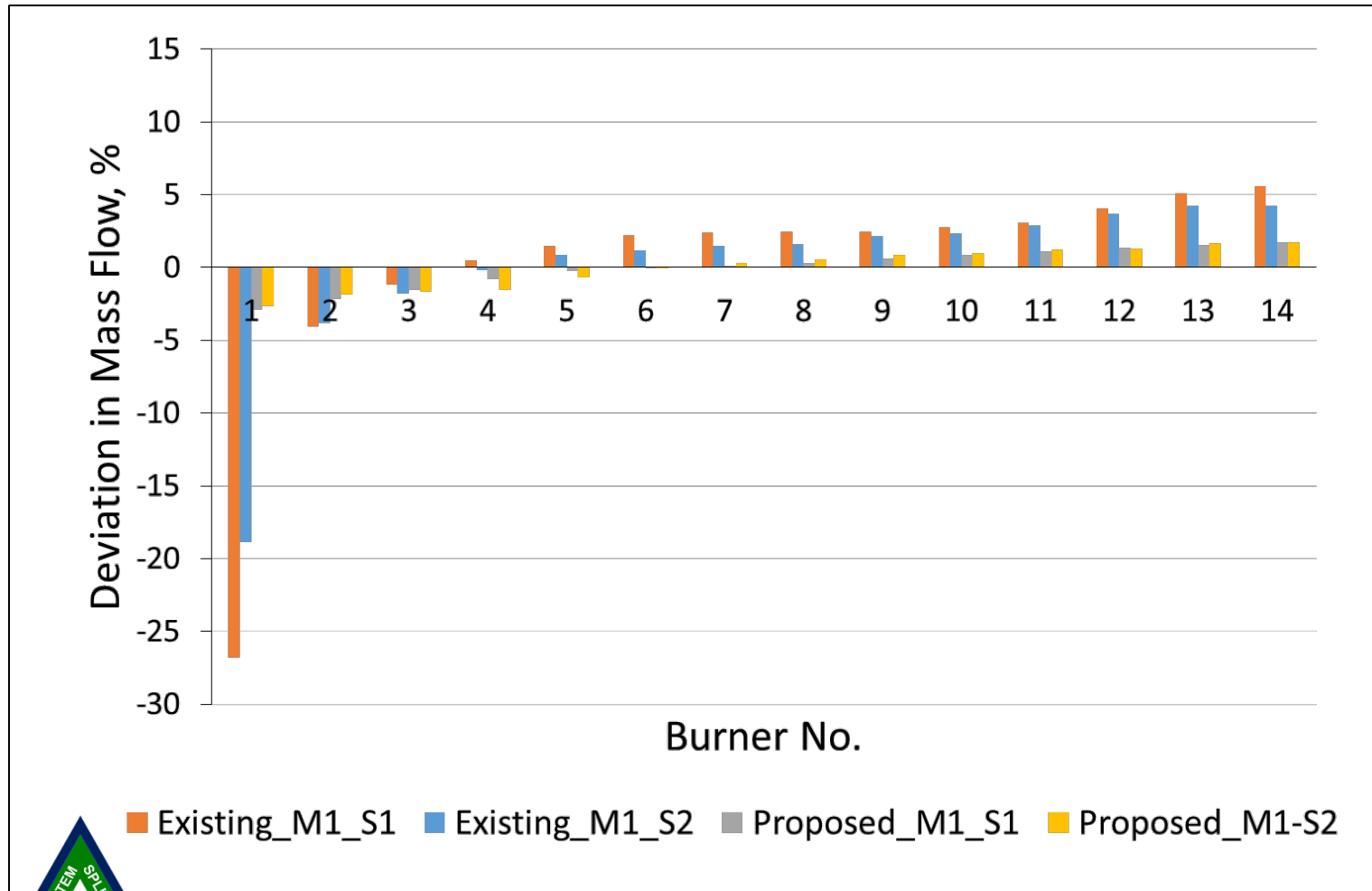

- Mass flow distribution across all the burners is significantly improved for the proposed case
- Improved air flow distribution across burners for other ducts is similar

Comparison

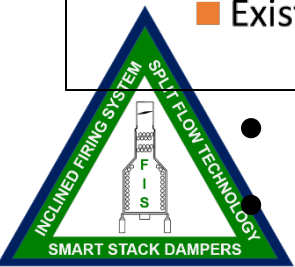

- Deviation from average flow rate per burner based on simulation results

Hot Flue Gas Inlet Duct to Air Preheater

[ft/s]

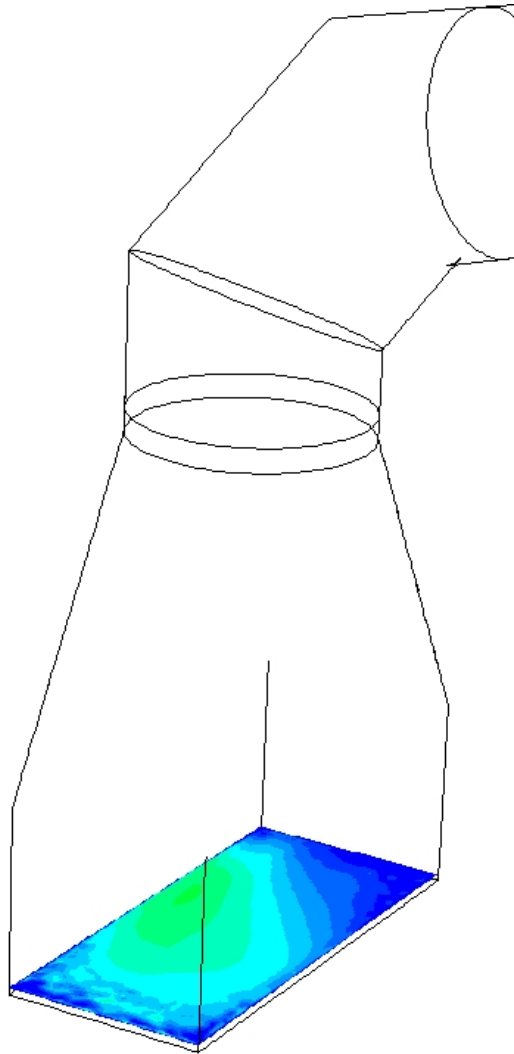

Existing

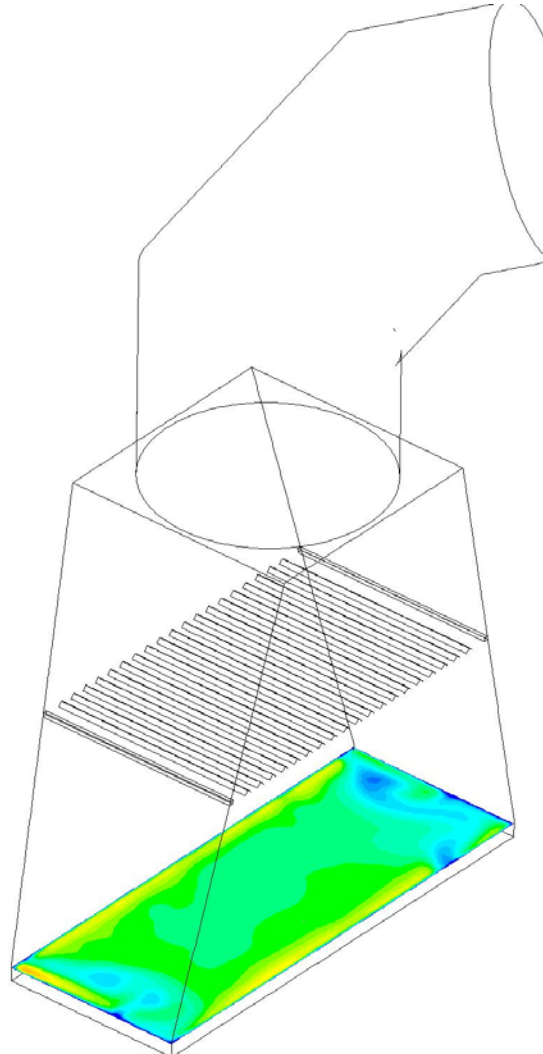

Proposed



Flue Gas Velocity Profile at ID Suction

[ft/s]

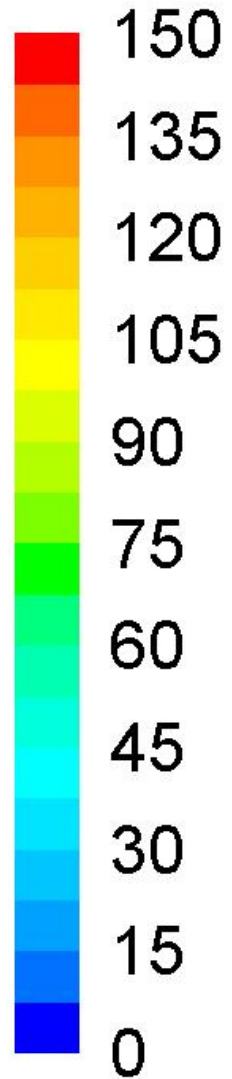

Velocity distribution throughout the duct has improved in the proposed case

Significant reduction in the recirculation zone for the proposed case

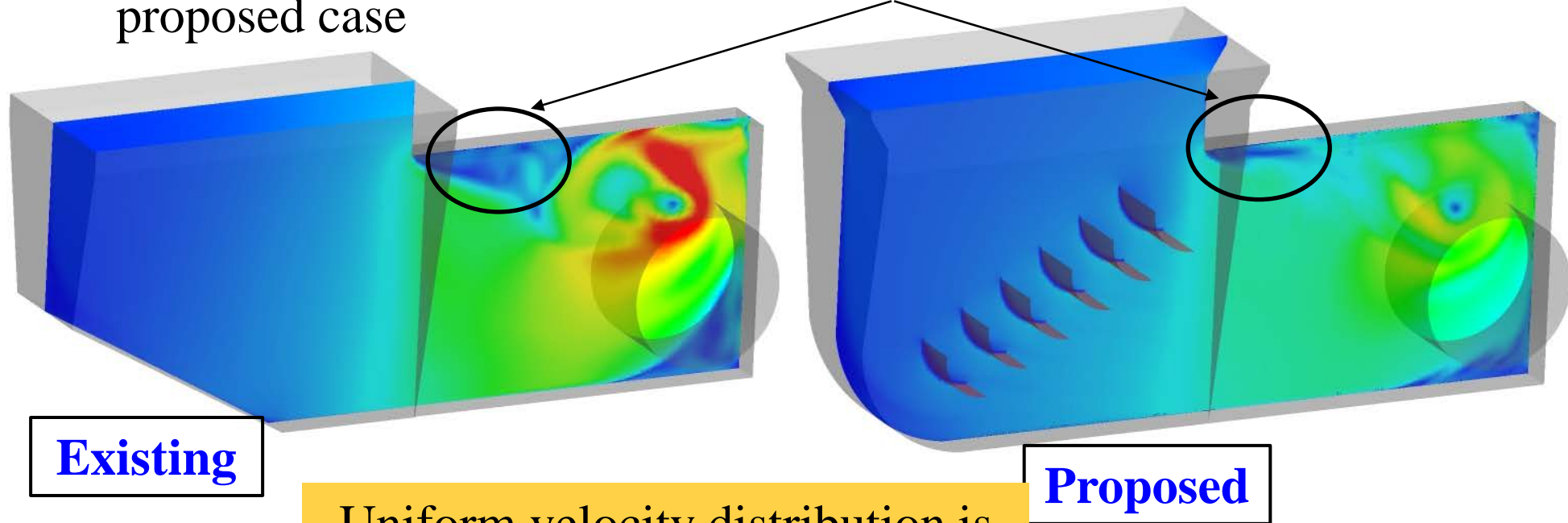

Existing

Proposed

Uniform velocity distribution is achieved at the inlet of ID fan for proposed case



Flue Gas Velocity Path Lines at ID Suction



Flue gas flow separation at the bends is reduced

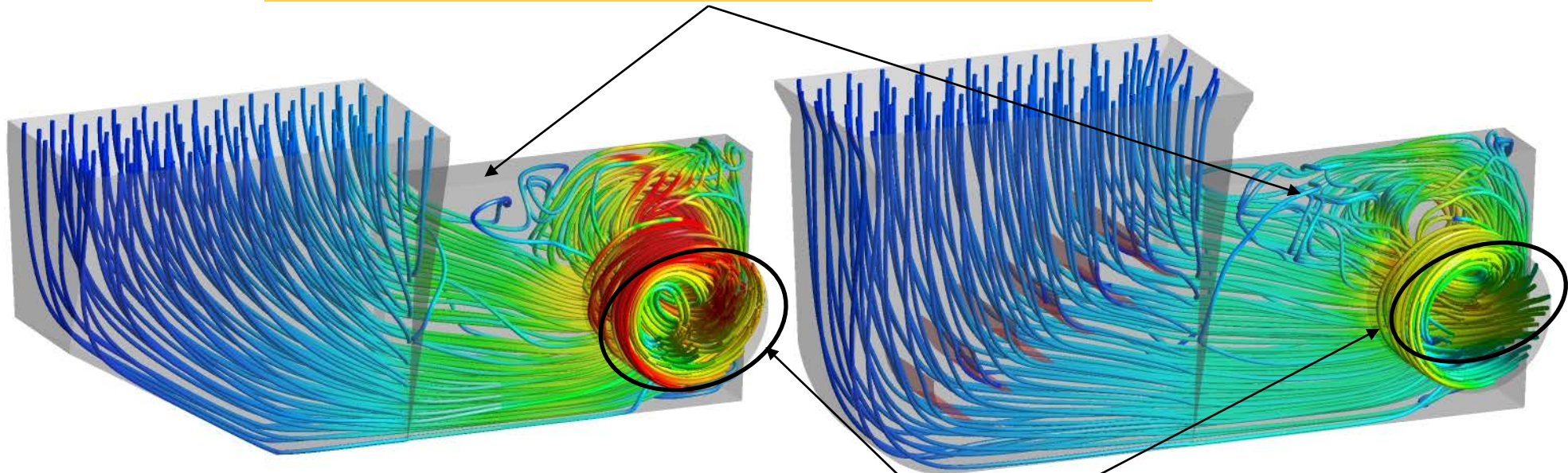

Significant reduction in swirling velocity near the inlet of ID fan

Existing

Proposed

Key Benefits

- Thermal Efficiency of the coker heater increased by 7-8% after the revamp.
- Heater production rate was improved after APH replacement.
- Production rate increased by 4,500 Barrels per day for each heater
- Overall project cost – Total \$7.5 Million for two heaters
- At about \$8 per Barrel it provided \$26 Million additional revenue per year
- Payout -4 months



Thank You!

